

Simulation of MIL-STD-187-721C Automated HF Networking

Eric E. Johnson
New Mexico State University¹
Las Cruces, NM, USA

Robert Desourdis
Science Applications International Corp. (SAIC)
Marlborough, MA, USA

Matthew Rager
Germantown, MD, USA

Abstract

Recently developed technology for automated HF networking has been standardized in the U.S. in MIL-STD-187-721C. This protocol suite attempts to provide near 100% connectivity among dispersed HF stations through the use of adaptive routing, employing both frequency and geographic diversity.

This paper describes the results of a simulation study of these protocols under realistic message loading, using ICEPAC predictions of link connectivity among a representative set of stations. We find that the protocols adapt well to link outages and station congestion under a range of adverse operating conditions.

Introduction

The ionospheric propagation that makes high-frequency (HF) radio a versatile and cost-effective long-haul communications medium presents severe challenges to communications system designers, due to large fluctuations in the channel impulse response on every conceivable time scale:

- Noise impulses with nanosecond to microsecond durations.
- Multipath effects on the scale of milliseconds.
- Fading that lasts seconds to minutes.
- Diurnal and seasonal variations in usable channels from hour to hour and day to day.
- Solar cycle effects that vary from year to year.

It is well known that these channel characteristics must be addressed by a suite of techniques:

- The faster fluctuations are handled by appropriate modulation, equalization, and forward error correction in HF modems [1].
- Intermediate-term variations are addressed by retransmissions within data link protocols [2].
- Longer-term outages can be overcome by a combination of frequency- and geographic diversity [3].

In this paper, we present results of a simulation study of the recently completed suite of HF automation techniques and protocols contained in MIL-STD-188-141A [4] and MIL-STD-187-721C² [5]. These techniques and protocols, including automatic link establishment (ALE), link quality analysis (LQA), connectivity exchange (CONEX), and automatic message exchange (AME), are described in the next section. The following sections describe a hierarchical event-driven simulator that is being developed to assist system engineers in designing automated HF networks; an example network (the Russian Nuclear Power Plant Emergency Network) to which this simulator was first applied; and an analysis of the results of this first series of simulations.

¹ This work was supported in part by an equipment grant from the U.S. Army Research Office.

² The FED-STD-104x/105x series of standards specifies identical protocols for data-link-layer functions, such as ALE and the HF Data Link Protocol, but does not yet address the network layer functions discussed here.

Second-Generation HF Automation

The techniques for HF radio automation specified in MIL-STD-188-141A and MIL-STD-187-721C (and the corresponding FED-STDs) compose the so-called “second generation” of HF automation. These techniques grew out of the proprietary “first-generation” techniques, which were principally concerned with selective calling.

Figure 1 depicts many of the functions specified in the MIL-STDs in terms of the usual protocol layers. For our purposes, the data link layer is concerned with establishing links among stations for voice or data use, and for reliably conveying data messages over those links. The network layer is concerned with finding and using indirect paths (via relay stations) when direct paths are not available.

In this section, we describe four of these functions: automatic link establishment and link quality analysis at the data link layer, and connectivity exchange and automatic message exchange at the network layer.

Automatic Link Establishment (ALE)

Automatic link establishment comprises a set of techniques and protocols that together automate the task of finding usable frequencies and establishing links between automated stations. The key points include the following:

Robust Modem and Coding: The modem used for ALE employs 8-ary FSK modulation at 125 symbols per second, which is robust to multipath spreads of several ms. Triple redundancy with 2-of-3 voting, a short interleaver, and the extended (24,12,3) Golay code work together to support ALE operation at 0 dB 3 kHz SNR in CCIR Good and Poor channels.

Selective Calling: Each station is assigned one or more addresses, and only responds to calls that carry one of those addresses.

Scanning: Stations that are not linked continuously scan a set of assigned frequencies, listening for calls addressed to them. Stations that are attempting to link transmit calls of sufficient duration to capture scanning receivers.

Sounding: Calling stations select frequencies for linking attempts based upon records of which channels have recently carried signals from other stations of interest. This process is assisted by the periodic transmission of short self-identifying signals by idle stations; these transmissions are called “sounds” in the ALE standards.

It should be noted that these sounds constitute a source of spectrum pollution, and must therefore be employed judiciously so that overall system performance is optimized. For large networks, it is critical that simulation or equivalent analytical tools be employed to determine the best sounding strategy.

Link Quality Analysis (LQA)

Recording the occurrence of sounds on assigned channels provides a source of binary channel evaluation: each channel is believed to be either working or not working to a distant station, but no further information is available for ranking channels for the order of linking attempts. In addition to this simple scheme, the ALE system can combine measurements of channel quality from its own signaling with measurements made by external equipment to form a link quality matrix. This table stores the most recent information about the quality of the channel using each assigned frequency to all stations of interest. ALE controllers will also record link quality measurements from sounds received from other (non-preprogrammed) stations as well.

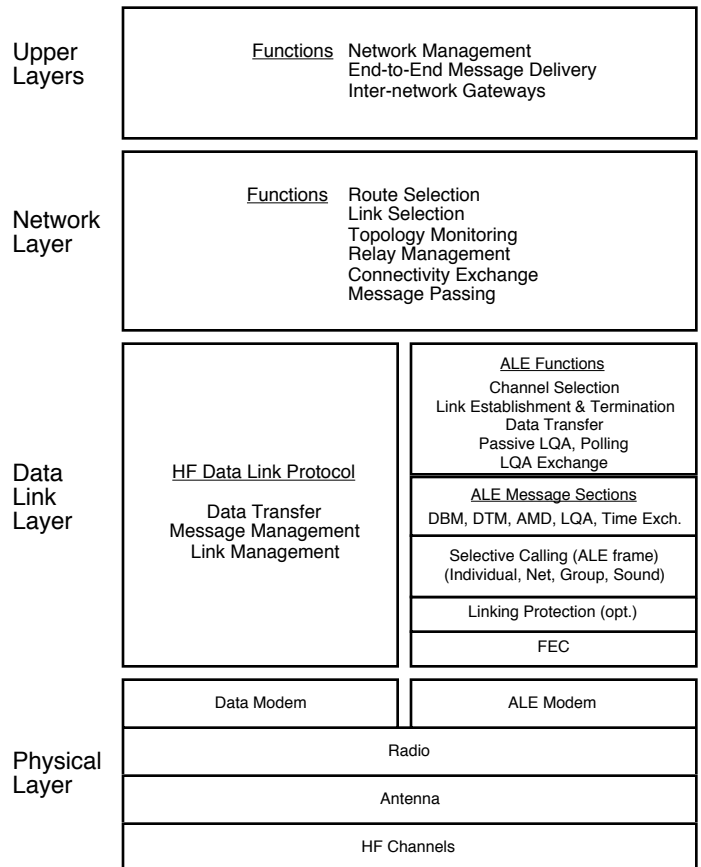

Figure 1: HF Automation Functions

Connectivity Exchange (CONEX)

When attempts to link directly with a station have failed, it is often possible to convey messages to the called station indirectly via a relay station that can directly reach both the calling and called stations. The CONEX protocol may be used by potential relay stations to inform potential clients of the destinations reachable by the relay station. A CONEX broadcast carries a list of reachable stations, along with an aggregate path quality (similar to an LQA score) that describes the noise or error level expected for the path from the relay to each destination. A station receiving a CONEX broadcast computes the overall path quality to each destination, including the quality of its link to the relay.

Other routing information protocols are specified in MIL-STD-187-721C, including connectivity monitoring and query routing, but will not be discussed here.

Automatic Message Exchange (AME)

The routing functions at each station reside in a “node controller” or HFNC. Each HFNC manages all data link controllers at its site, possibly including multiple ALE controllers, HF data modems, and land-line, microwave, and satellite links. Voice and data traffic is routed by the HFNC using all connectivity and cost information available, including preprogrammed data, CONEX data, and local measurements.

Each HFNC³ is capable of routing traffic, and storing traffic locally when no path is available to the desired destination. The automatic message exchange protocol is the network-layer procedure for delivering messages from one station to the next along a direct or indirect path. The AME header contains fields for specifying precedence and quality of service desired, the “port” number of upper-layer protocols, and suggested or mandatory relay stations.

Hierarchical HF Networking Simulator

This section presents an overview of a hierarchical simulation suite for automated HF radio networks. As shown in Figure 2, the simulation suite is structured similarly to the protocol stack shown in Figure 1. All of the modules are independent, and communicate with each other (and with multiple instances of themselves) using “events.” For example, each instance of the Mailer (the message generator) sends itself events to prompt future messages, and also uses events to deliver messages to be sent to other stations to the instance of the HFNC module that simulates its local HFNC.

Each module may simulate its corresponding entities to whatever degree of detail is appropriate for an investigation. For example, since channel occupancy and the use of relaying are of primary interest in the project reported here, the HFNC is simulated in full detail while the ALE controller is simulated only at the level of complete transmissions (rather than modem tone samples as in previous simulations).

Channel Simulation

In any HF radio simulation, the model used for the channels is of critical importance. This is especially true for network simulations, because many of the interesting effects result from the differences in propagation among the stations. For example, station A may be transmitting to station B on a frequency that propagates between B and C, but not between A and C. As a result, if C wishes to link with B, C may listen on the channel and, not hearing the transmissions from A, begin transmitting to B and interfere with the transmission from A.

The approach used in the simulations reported here uses hourly SNR predictions from ICEPAC for each frequency and

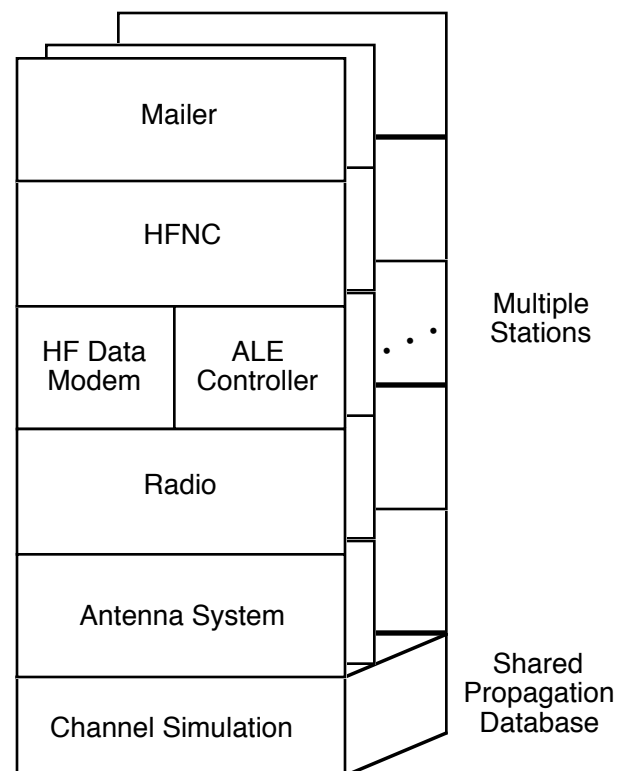

Figure 2: Simulator Structure

³ MIL-STD-187-721C defines several “levels” of HFNC functionality. All but the lowest level are capable of store-and-forward operation.

each station pair to be simulated. Specifically, denoting the hour by subscript h , the frequency by subscript f , the sending station by subscript s , and the receiving station by subscript r , we obtain the first, fifth, and ninth deciles of the 3 kHz SNR, S_{1hfsr} , S_{5hfsr} , and S_{9hfsr} from ICEPAC, and store these in global arrays in the simulator. When the SNR on a link is required during simulation, the appropriate set of three channel parameters is retrieved, three uniformly-distributed random numbers u_1 , u_2 , and u_3 are drawn, and an estimate of SNR_{hfsr} is computed as follows. First, a normally distributed random variable z is computed from u_1 and u_2 . Then u_3 is used to determine whether the SNR value will be above or below the median:

$$z = \cos(2\pi u_1) \sqrt{-2 \ln(u_2)}$$

$$SNR_{hfsr} = \begin{cases} S_{5hfsr} - z \left(\frac{S_{5hfsr} - S_{1hfsr}}{1.28} \right) & u_3 < 0.5 \\ S_{5hfsr} + z \left(\frac{S_{9hfsr} - S_{5hfsr}}{1.28} \right) & u_3 \geq 0.5 \end{cases}$$

ALE Simulation

Each ALE controller is simulated as a state machine that is either scanning, or stopped on a channel in one of the following states: listening before sounding, sending a sound, listening before calling, calling, linking, or linked. When a station is not scanning, it can only receive a transmission if it is stopped on the channel carrying that transmission and it is not itself transmitting. Thus, an ALE controller will sometimes miss receiving a sound, resulting in disparate records of link quality among ALE controllers.

Whenever an ALE controller initiates a transmission, the channel simulation is invoked to estimate the SNR to all other stations. The resulting estimates are converted to the LQA scores that would be measured by the receiving station, and these scores are appended to events that are sent to the potential receivers. (As mentioned above, some stations will be otherwise occupied, and will ignore the event.) The LQA scores from received sounds or other ALE transmissions are recorded by each ALE controller in its LQA table, and the local HFNC is notified of significant changes in connectivity. With the passage of time, LQA scores that have not been updated by more recent data are steadily degraded, until they reach “unknown” link quality.

Each ALE controller uses its LQA table for selecting channels for linking attempts. When channels have identical LQA scores, the ALE controller will try the highest frequency among the tied channels. This, along with missed sounds that arrived while the ALE controller was busy, and the use of outdated LQA data, can result in link establishment on channels that are suitable for linking, but not the best channels available. This behavior is faithfully reproduced by the simulated LQA controller.

As with other transmissions, linking attempts may fail to propagate, may arrive corrupted, or may arrive at a receiver that is not listening on the selected channel. In such cases, the linking attempt fails, prompting the calling ALE controller to downgrade the LQA of the failed channel, and try again on another channel. The calling ALE controller will abandon the attempt to link after a preset number of failures (set to 5 here), and will notify its HFNC of the lack of connectivity to the destination. For the simulations reported in this paper, the linking probabilities were derived from the SNR values described above, using tables generated from previous simulations with 2 ms multipath spread and 2 Hz Doppler spread.

HFNC Simulation

The HFNC module maintains a path quality matrix, which lists the quality of the best path via every relay station to every reachable destination. A routing table is extracted and continuously updated from the path quality matrix. The routing table identifies the best relay station for use in reaching every destination.

The HFNC also assigns groups of equipment (e.g., ALE controllers, radios, PAs, and antennas) to “strings,” and tracks the state of each such string. Although the stations simulated here each contained only a single string, key stations in large networks may have several strings to simultaneously handle links to multiple destinations.

HF Network Optimization Using Simulation

An example HF network that has been evaluated using this simulator is the Russian Nuclear Power Plant Emergency Network. The goal of this simulation was to predict the availability of links to a central node from the other network stations under realistic propagation conditions. The network was evaluated as originally designed, and with two optional improvements: the addition of a relaying capability, and the use of additional frequencies.

The Russian Nuclear Power Plant Emergency Network

The establishment of a reliable, high quality communication system is an integral part of emergency response systems that have been developed throughout the world for nuclear power plants. The communication system provides a link to the outside world for the staff of a nuclear power plant that has experienced and/or is managing events that could range from unusual operational transients to severe reactor accidents that could threaten local populations. The systems typically comprise a system for daily communications and an emergency communication system.

The communication systems that are currently in use for nuclear power plants within Russia and other countries of the Former Soviet Union rely upon various telephone systems. These telephone systems have historically provided unreliable service. Although they are acceptable for daily reports, they are not considered a desirable vehicle for supporting emergency communications. In order to provide the Russian nuclear complex with a reliable system for communications during incidents which may range from off-normal events to severe accidents, the U.S. Nuclear Regulatory Commission is currently supporting the development and deployment of a prototype communication system that relies on HF communication links. This prototype system provides a reliable communication link between the nuclear power plant and the federal nuclear regulator, Gosatomnadzor (GAN). This communication link may eventually be expanded to provide a reliable communication link that could be accessed in parallel by the operating nuclear utility with Headquarters in Moscow, and other federal agencies and ministries tasked with managing related elements of accident response at these facilities.

The prototype communication system being deployed in Russia includes HF communication modules at GAN Headquarters in Moscow and at the Kalinin Nuclear Power Plan (NPP) in Udomlya and Leningrad NPP in Sosnovy Bor (Figure 3). The HF communication modules comprise an HF transceiver and 1 kW power amplifier located off-site (i.e., away from the electromagnetic fields created by the transmission lines present at the power plant). An on-site ALE controller remotely commands the off-site RF equipment.

Network Design Options

The emergency communication system is intended to provide year-round, high quality voice and data transfer capabilities between NPPs located throughout Russia and the regulator in Moscow, thereby assuring that the status of the NPPs can be ascertained at any time. The metric for gauging the performance of the network is the latency in communicating a 4500-bit emergency message from an NPP to Moscow (M). 30 minute latencies are minimally acceptable.

ALE sounding and occasional communication checks constitute the only ongoing load on the network. Thus, emergency message latency is a function principally of the time required to establish a link with Moscow from the NPP station. When the frequencies assigned to this network do not support communication between an NPP station and Moscow, relaying may be able to bypass the propagation outage and substantially shorten the latency. As another alternative, additional frequencies may be made available if the current frequencies prove inadequate. The following three network designs were therefore considered:

- Four frequencies (4.9, 5.9, 7.5, and 8.1 MHz), with no relaying capability (the baseline configuration).
- The same four frequencies, with relaying capability added.
- Ten frequencies (the four above, plus 3.5, 3.6, 7.1, 7.1, 10.1, and 14.1 MHz), without relaying.

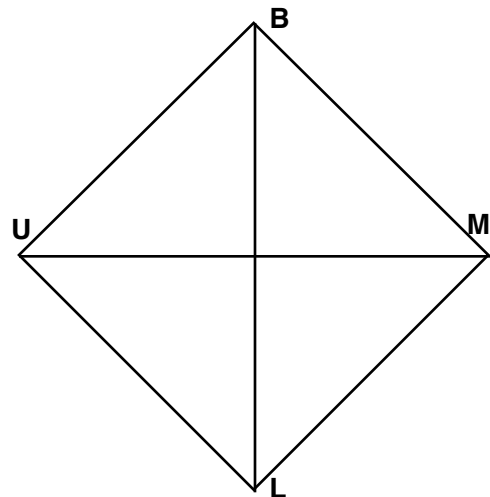

Figure 3: The Prototype Russian Nuclear Power Plant Emergency Network

Simulation Results

Simulation of the Russian Nuclear Power Plant Emergency Network demonstrates the value of both frequency and geographical diversity. Figure 4 below illustrates the expected latency of delivering an emergency message from station U to station M under the following sets of conditions:

- Direct: Four frequencies, no relaying.
- Relays: Four frequencies, with relaying.
- 10 Ch: Ten frequencies, no relaying.

Each station sent a sound on each channel twice per hour. The Moscow node polled each other node twice per day for a short data message. Although a CLOVER modem is available at each node, the ALE message protocols (Data Text Message mode and Data Block Message mode) were used for message delivery. The predicted throughput of these protocols on the channels available exceeded recently measured performance of the CLOVER system [6].

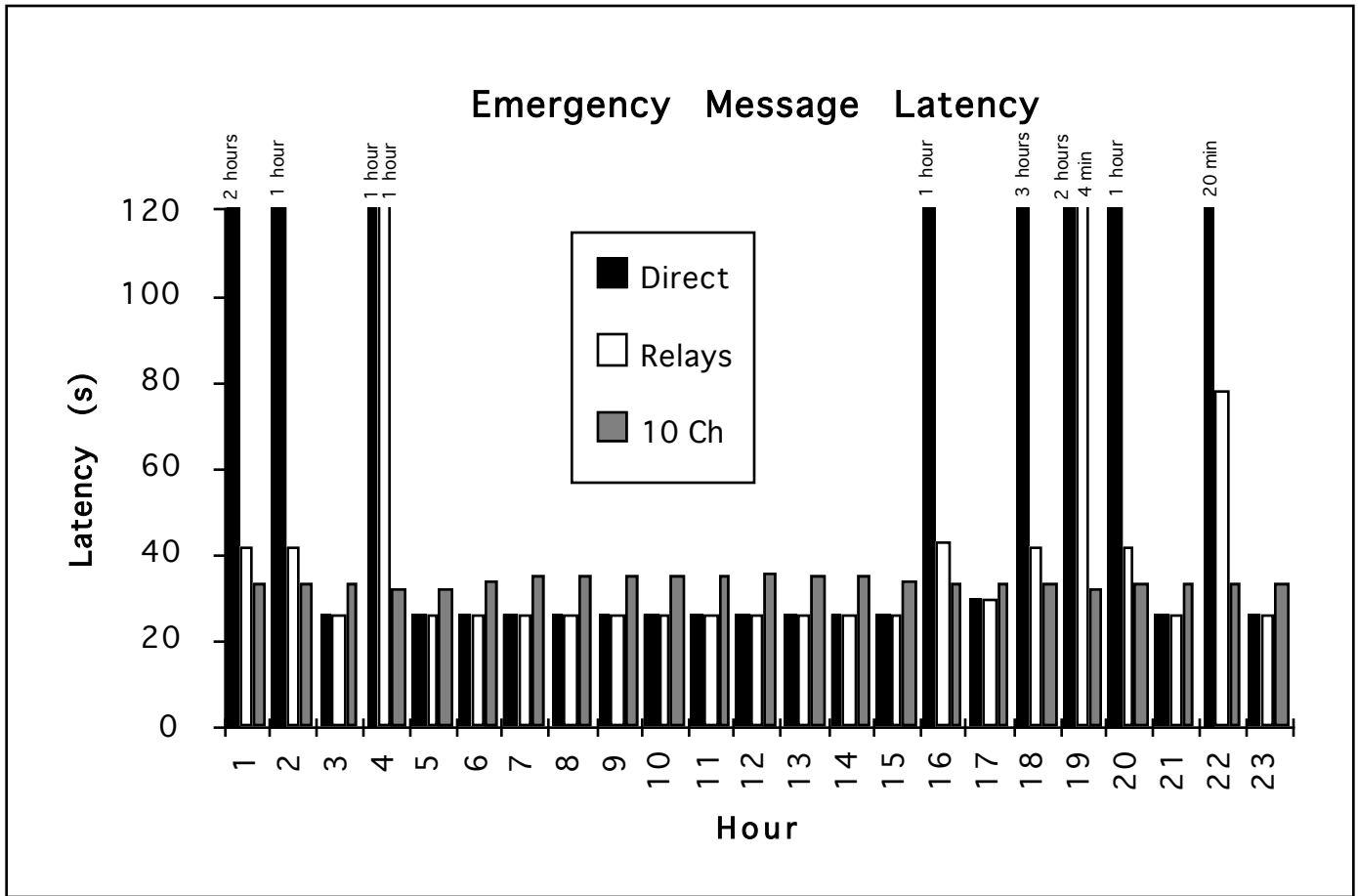

Figure 4: Emergency Message latency

In these simulations, channel congestion was not observed to be a significant problem, as expected from the light channel loading. Some station congestion was observed, as nodes occasionally missed receiving sounds while they were sounding. At the Moscow node, station utilization was normally about 4% with 4 channels, and 23% with 10 channels, except for one hour during the 4-channel simulation. In that hour, marginal propagation to one station resulted in extended retries of the polling message, and a resulting 57% utilization of the Moscow node. At the other stations, utilization was 2-4% (night and day) for the 4 channel case and 10-22% for 10 channels.

The overall performance of the three network designs is summarized in Table 1 below. The increased median latency for the 10-channel network is due to the longer sounds and scanning calls necessary to cover the additional channels. Note that the addition of relaying capability to the 4-channel design nearly eliminates the outages encountered in the baseline network, and the use of additional channels entirely eliminates the outages.

Table 1: HF Network Performance

Network Design	Median Latency	Worst Latency	Outage Hours
4 channels, no relaying	26 s	3 hr	7
4 channels with relaying	26 s	1 hr	1
10 channels, no relaying	33 s	36 s	0

Conclusions

The simulator described in this paper can be employed to evaluate the performance of HF radio networks at several levels in the protocol hierarchy. In the case study presented here, both propagation effects and the added connectivity provided by relaying were investigated for a real-world ALE network.

- As originally designed, outages of up to three hours occur, due to the loss of propagation on all four assigned frequencies.
- The benefit of geographical diversity, captured by the relaying capability, was seen to nearly eliminate the propagation outages caused by the limited set of frequencies.
- When a total of ten frequencies is available, the ALE system is able to find propagation throughout the day, without recourse to relaying.

The simulator is able to use previously generated results to reduce simulation runtime. A planned enhancement to the simulator is an ability to dynamically spawn “sub-simulations” to fill in gaps in such data.

Acknowledgments

The authors are grateful to Mr. Joseph Himes, the U.S. Nuclear Regulatory Commission's Project Officer for the Prototype Emergency-Communication System in Russia.

References

1. MIL-STD-188-110A, “Interoperability and Performance Standards for Data Modems,” 30 September 1991.
2. Johnson, E.E., “Asymptotic Throughput of the FED-STD-1052 Data Link Protocol,” submitted to the 1996 *IEEE Military Communications Conference (MILCOM '96)*, October 1996.
3. Goodman, J., *et al.*, “Middle and High Latitude HF Channel Assessment Campaign – Experimental Description and Initial Results,” presented at *HF '95 Nordic Shortwave Radio Conference*, August 1995.
4. MIL-STD-188-141A, “Interoperability and Performance Standards for Medium and High Frequency Radio Equipment,” Notice 2, 10 September 1993.
5. MIL-STD-187-721C, “Interface and Performance Standard for Automated Control Applique for HF Radio,” 30 November 1994.
6. Redding, C., “HF Packet Radio Modem Protocol Testing,” reported at HF Industries Association meeting, San Diego, CA, 25 January 1996. To appear in *QST*.